



Dimensions

Height	2 275 mm
Width	1 946 mm
Length	3 643 mm
Number of Cutters	30
Cutter Thickness	40 mm
Motor Power	2 x 22kW
Approx Weight	5 250 Kg

Cutting Chamber

Length	1212 mm
Width	736 mm

Features

- Dual Motors
- Ideal for, E-Waste, Drums, MSW and Product Destruction
- Auto Reverse Protection
- Easy Maintenance
- Reliable & Durable Construction
- Low Speed - Low Maintenance
- Generous Loading Aperture

Optional Extras

- Additional Force Feeding Ram
- Rotating Material Sizing Screens
- Multiple Blade Variations
- Custom Hopper Designs
- In-Feed and Out Feed Conveyors
- Elevated work and loading platforms



Dimensions and technical information without obligation. Subject to change.

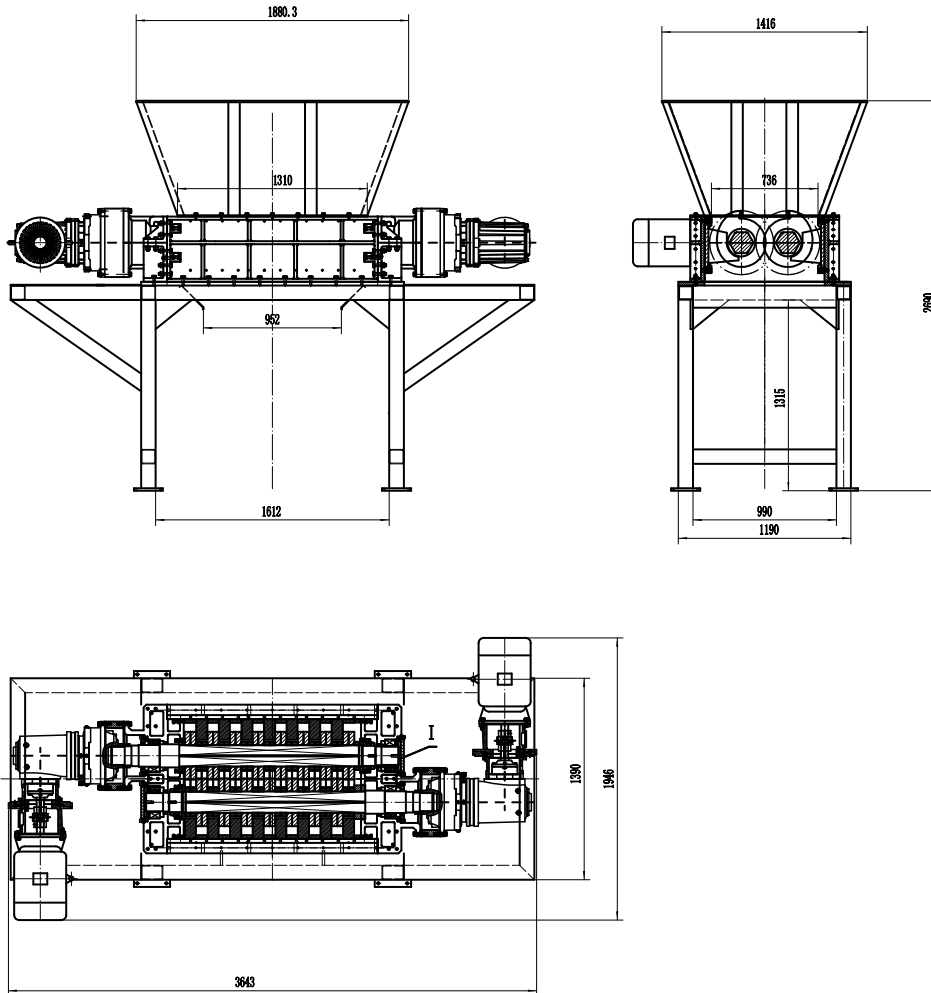

Size Comparison



Shaft Type
2 Shaft Shredder



Cutters
x30 (40mm thick)



Motors
2 x 22kW



Waste Types
Tyres, E-waste,
Paper, Wood, Bottles,
Cans, MSW/RDF ...

