



Dimensions

Height	2 530mm (without hopper)
Width	2 221mm
Depth	1 760mm
Weight	3 650 Kg
Feed Width	1234 x 540mm
Roto Knives	3 x 2

Performance

Power Supply	415V 3 Phase
Motor	55 kW
Shaft Speed	462rpm

Features

- Hardened steel rotor knives
- Material sizing screens
- Auto Reverse Protection
- Easy Maintenance
- Reliable & Durable Construction
- Control Panel
- Generous Loading Aperture

Optional Extras

- Sound Proof Enclosure
- Various Rotors for different plastics
- In-Feed & Out-feed Conveyors
- Out-Feed Extraction Units
- Outfeed screw loaders
- Custom hopper design



Dimensions and technical information without obligation. Subject to change.

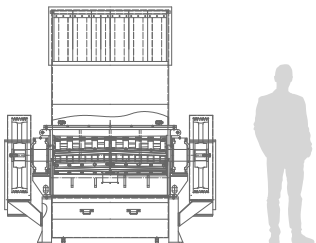
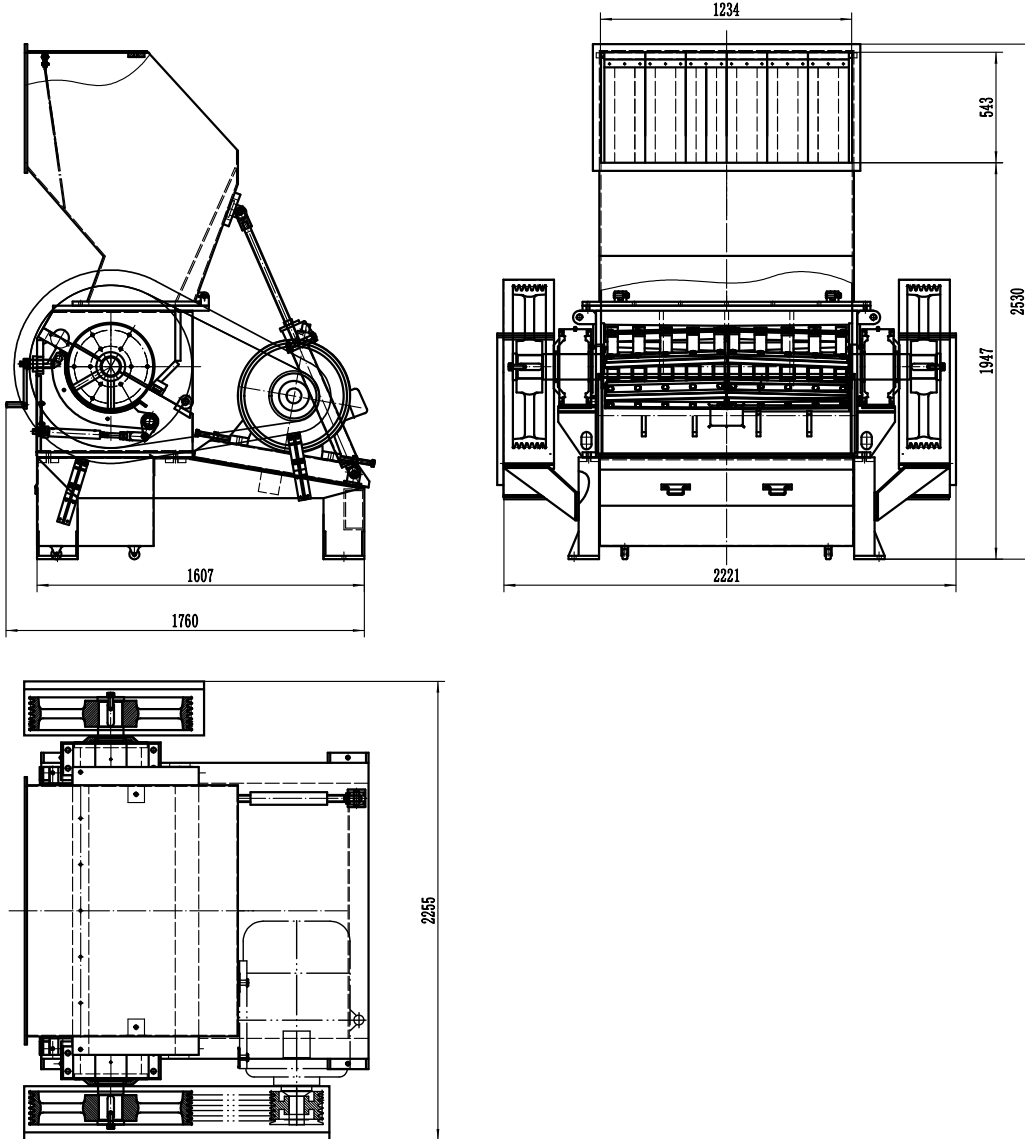

Size Comparison



Safety
E-Stops, AS
Standards,
Interlocked doors



Motor
55kW



Waste Types
Mixed Plastics, HDPE,
PET, Mixed Fabric,
E-waste ...

