

### Dimensions

Height	1 300mm
Width	1 500mm
Length	1 420mm
Chamber Opening (WxL)	1 400 x 1 200
Compaction density	Up to 250kg/ m <sup>3</sup> (cardboard)
Auger Diameter	800 -500mm
Power Supply	415V 3-phase

### Performance

Motor	11kW	15kW
Auger Speed	15rpm	17rpm
Weight	1 850kg	1 950kg

### Features

- High compaction force optimising transport payloads
- Suitable for a range of waste material
- Easy & safe to operate
- Robust design & build - engineered for long life and optimum performance
- Hour meter, full signal & 80% full signal included
- Built in power pack for security and safety of personnel
- Bin-away switch

[More product info on our website >>](#)



### Optional Extras

- "Whirler" feeder
- Heavy duty cardboard feeders
- Wood crusher feeders
- Custom feed hopper
- Wall chutes
- Infeed conveyor
- Material pre-shredder
- Bin tipper for in-feed
- Remote notifications and troubleshooting

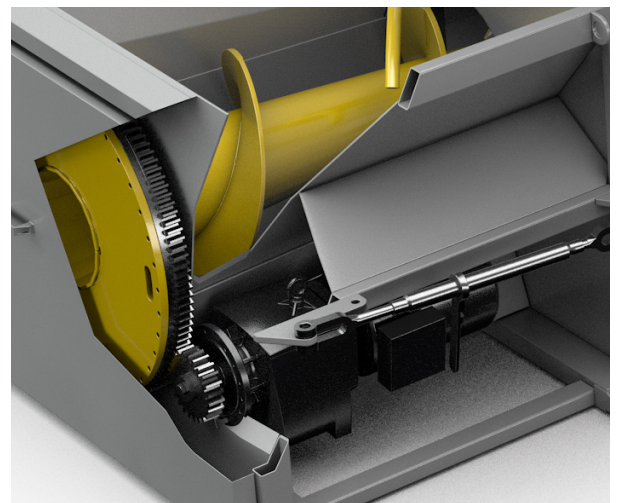

Dimensions and technical information without obligation. Subject to change.

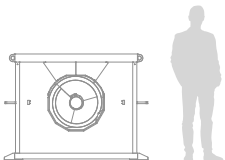
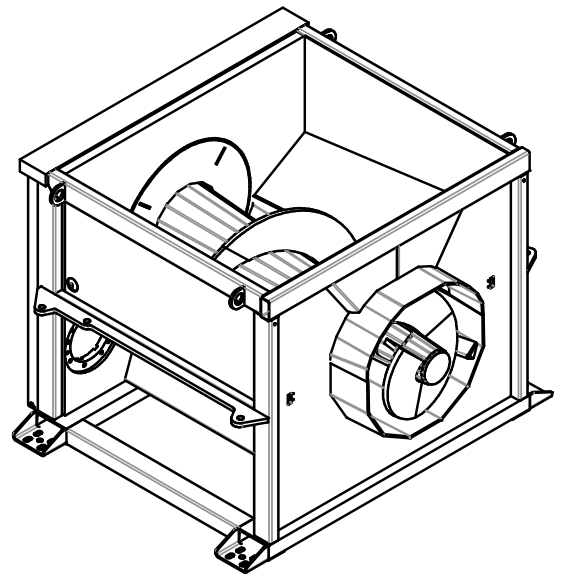
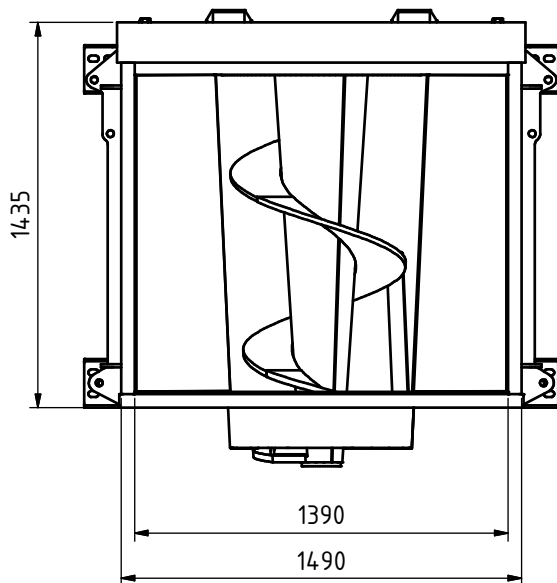
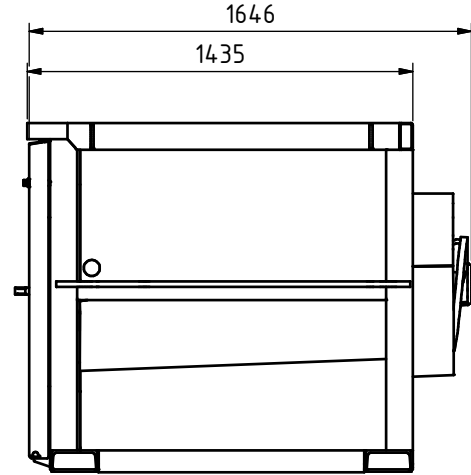
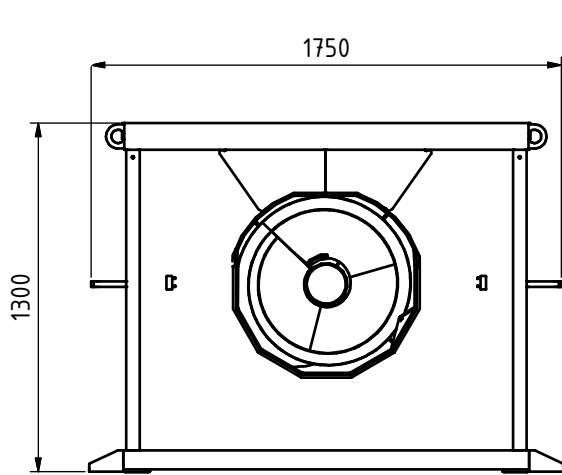

Size Comparison



**Compaction Ratio**  
Up to 6:1



**Motor**  
11kW | 15kW



**Waste Types**  
General Waste,  
Cardboard, Pallets,  
furniture Timbers

