



Baler Dimensions

Height	1 756 mm
Width	718 mm
Depth	614 mm
Weight	140 kg
Transportation Height	1 409 mm
Power Supply	240V 1 Phase
Motor	1.5kW 10A
Pressing Force	Up to 2T
Noise Level	62 dB
Cycle Time	20 Seconds

Bale Dimensions

Height	600 mm
Width	533 mm
Depth	460 mm
Weight	Up to 40kg

Loading Aperture Sizes

Height	483 mm
Width	533 mm

Baler Features

- Retaining claws to prevent spring back of material
- Bale full indicator
- 2 year warranty

Optional Extras

- Galvanised finish



Dimensions and technical information without obligation. Subject to change.

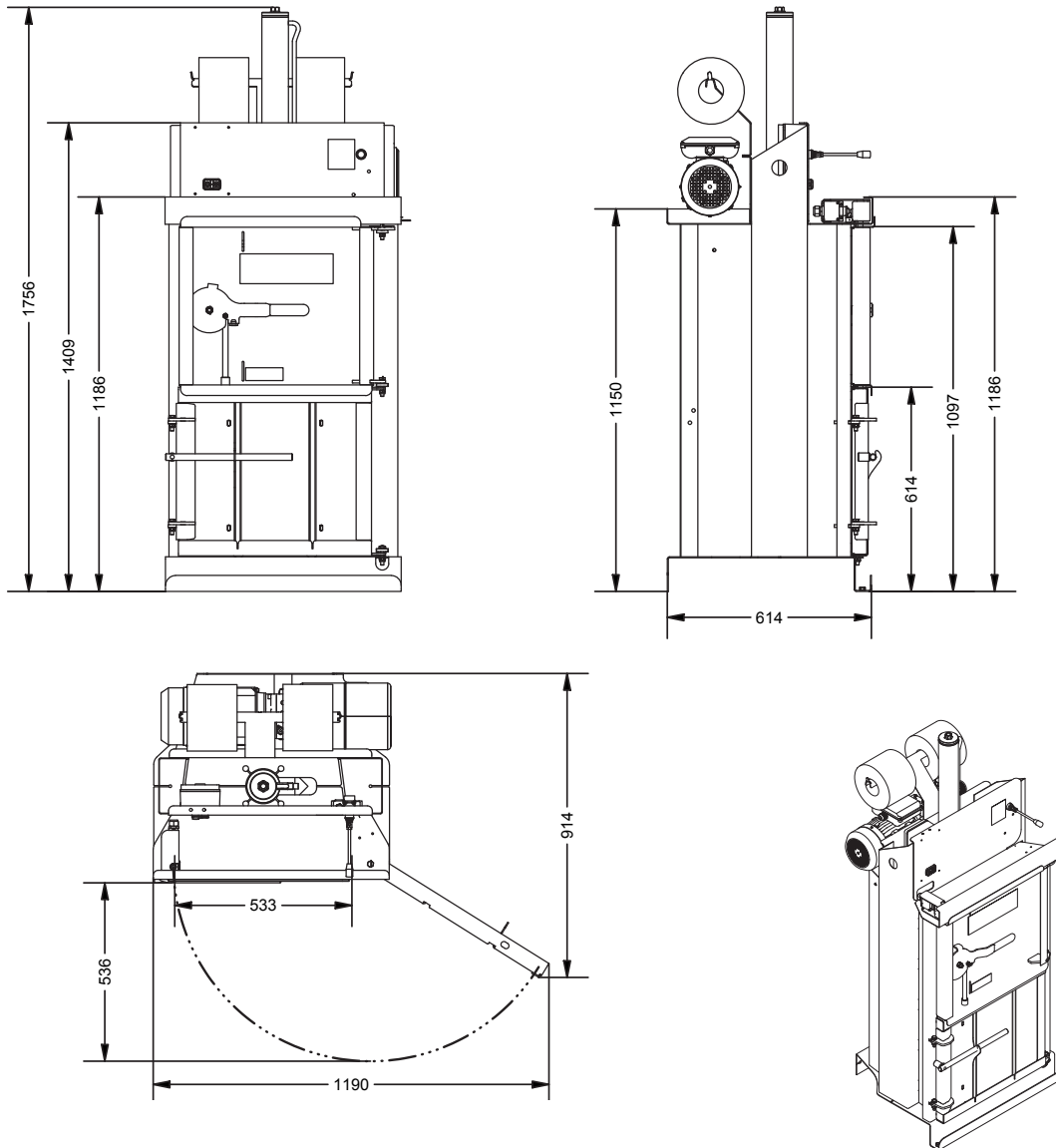

Size Comparison



Bale Weight
Up to 40 Kg



Pressing Force
Up to 2 Ton



Motor
1.5kW 10A



Waste Types
Cardboard, Plastic
Film, Paper, LDPE
Film ...

