



### Baler Dimensions

Height	2 343 mm
Width	2 050 mm
Depth	918 mm
Weight	562 kg
Power Supply	240V 1 Phase
Motor	2.2kW 15A
Pressing Force	Up to 8T
Noise Level	72 dB
Cycle Time	35 Seconds

### Bale Dimensions

Height	675 mm
Width	700 mm
Depth	503 mm
Weight	Up to 40kg

### Loading Aperture Sizes

Depth	503 mm
Width	700 mm

### Baler Features

- Unique piercing mechanism eliminates the need for removal of bottle caps before baling
- High compaction ratio
- Suitable for medium to large amounts of plastic bottles for disposal
- Top loading baler
- Bale Lifting Trolley included
- 30L retention tank with tap connection for collection of residual liquid left in bottles
- 2 year warranty

### Optional Extras

- Up to 6 additional chambers can be added
- Available with 3-phase power supply
- Galvanised finish



Dimensions and technical information without obligation. Subject to change.

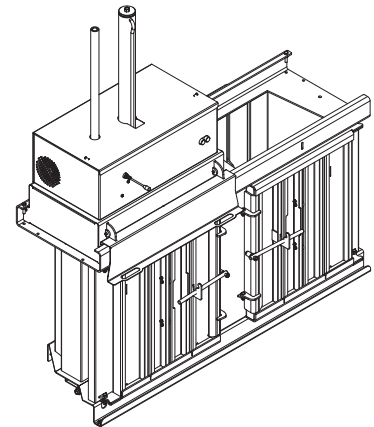
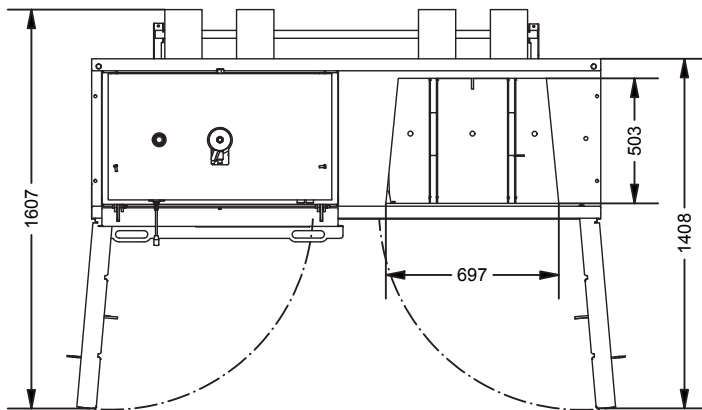
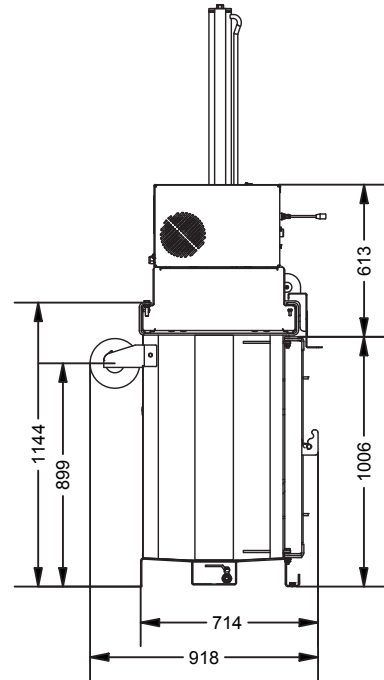
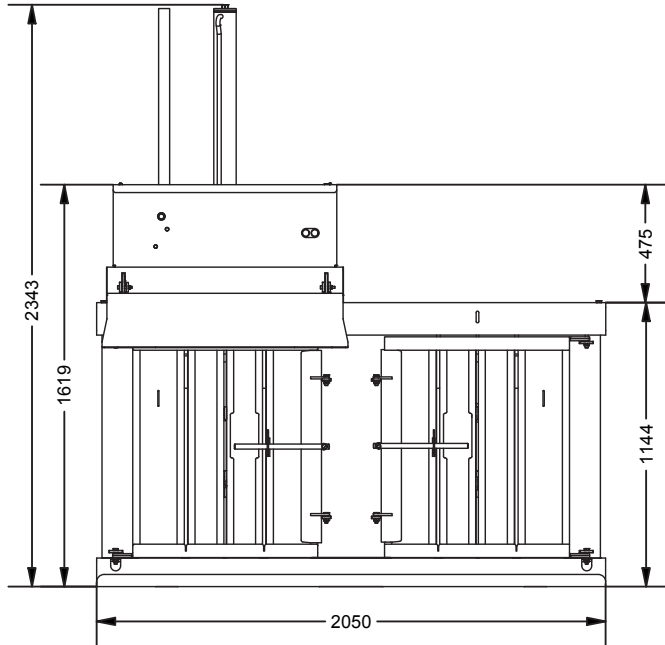

Size Comparison



**Bale Weight**  
Up to 40 Kg



**Pressing Force**  
Up to 8 Ton



**Motor**  
2.2kW 15A



**Waste Types**  
PET Bottles

