



## Dimensions

Height	1 898 mm
Width	1 195 mm
Depth	577 mm
Weight	325 kg
Power Supply	240V 1 Phase
Motor	1.5kW 13A
Pressing Force	Up to 3T
Noise Level	70 dB

## Bag Dimensions

Diameter	500 mm
Depth	1 000 mm

## Features

- High compaction force ratio 10:1
- Suitable for both wet & dry kitchen materials
- Top loading
- Split chamber for ease of bag removal
- Wheel mounted for quick & easy movement
- Low operating height



Dimensions and technical information without obligation. Subject to change.

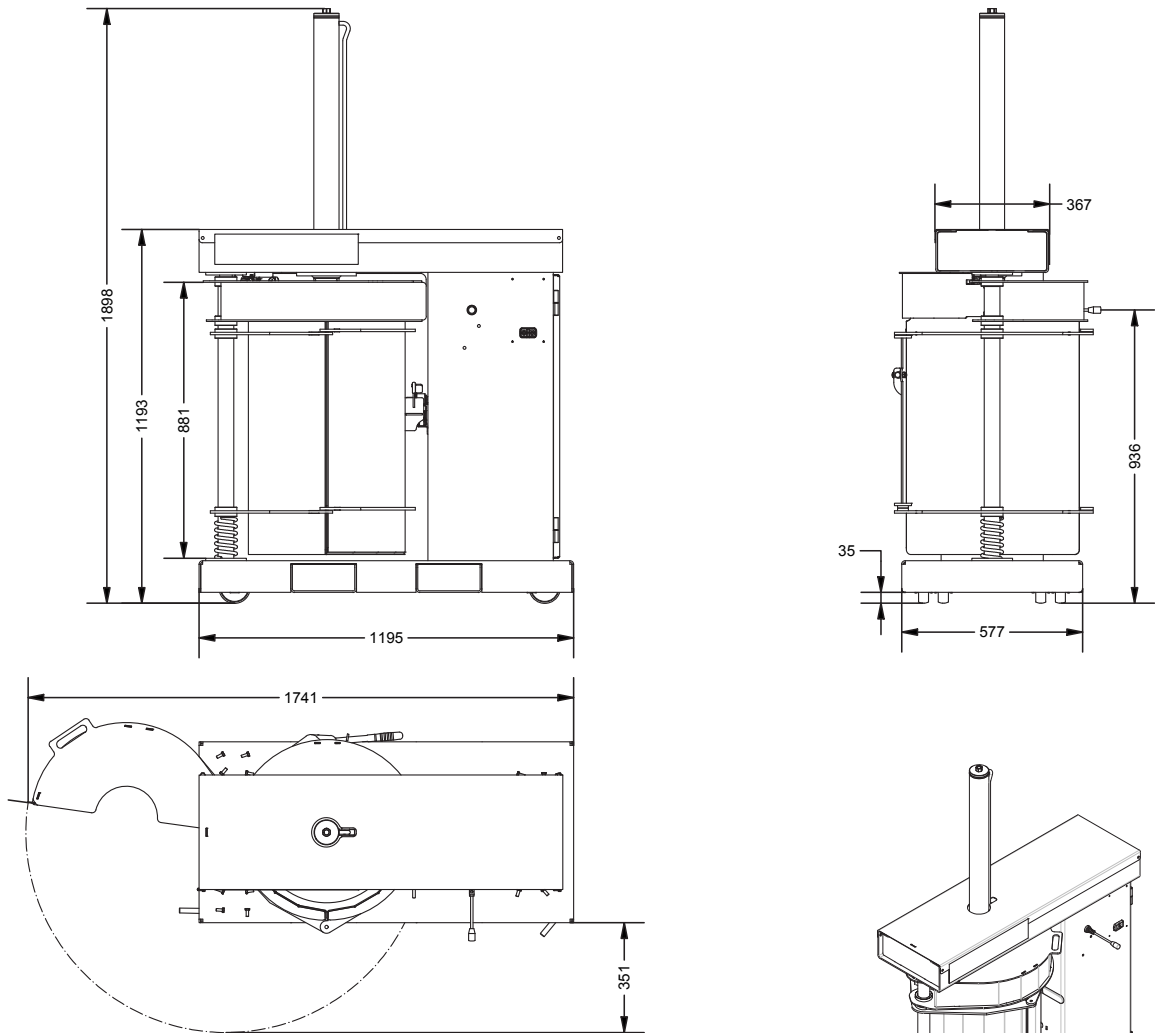

Size Comparison



**Compaction Ratio**  
Up to 10:1



**Pressing Force**  
Up to 3 Ton



**Motor**  
1.5kW



**Waste Types**  
Wet & dry kitchen/  
Foodcourt waste

