



Features

- Full bale ejection of each bale
- High-pressure and low-pressure baling modes
- Vertical hydraulic end door
- Bale counter, hour meter
- Hardox plated floor and press plate base
- V shaped serrated bale chamber shear blades
- Low level machine (loading height)
- High density mill sized bales

Optional Extras

- Fast cycle options from 60 – 40 seconds
- Range of power pack and motor options
- Bin Tipper for infeed
- Custom hopper design
- Auto start/stop functions
- Paint upgrade – custom colours

Baler Dimensions

Height	2 535mm
Width	1 290mm
Length	5 815mm
Weight	5.5T
Feed Opening	1 250mm x 710mm

Bale Dimensions

Height	750mm
Width	750mm
Length	1 200mm
Weight (material dependent)	up to 400kg
Number of ties	4

Performance

Power Supply	415 V 3-Phase
Motor	5.5kW 32A
Pressing Force	38T
Cycle Time	60 seconds

[More product info on our website >>](#)



Dimensions and technical information without obligation. Subject to change.

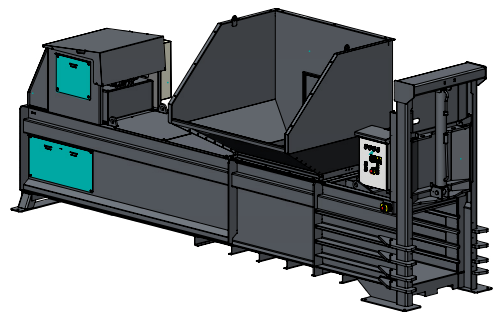
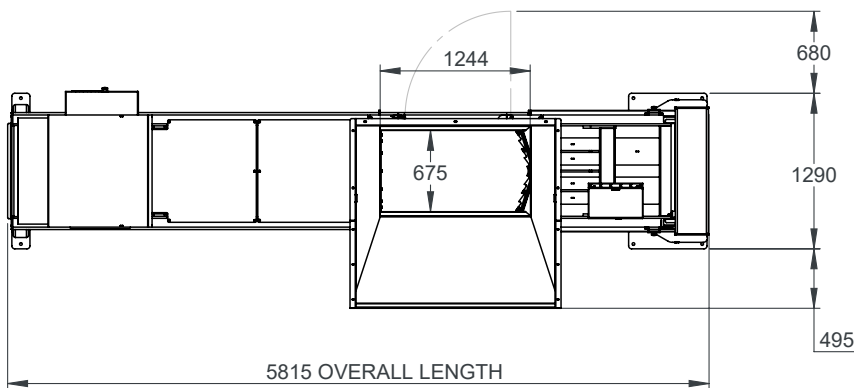
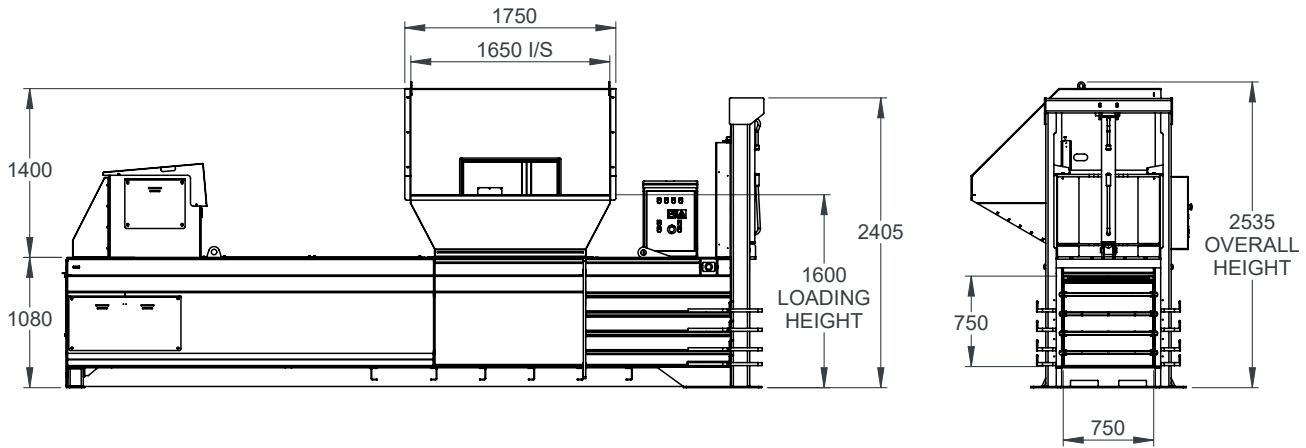

Size Comparison



Bale Weight
Up to 400 Kg



Pressing Force
Up to 38 Ton



Motor
5.5kW 32A



Waste Types
Cardboard,
General Waste &
Processed Food

