



**MAVITEC**  
Green Energy  
SOLE AUSTRALIAN DISTRIBUTOR



## Dimensions

Height	1 340mm
Width	1 070mm
Length	1 858mm
Motor	22-30 kW
Weight	1 100kg
Inlet	250 x 250 mm
Outlet	500 x 680 mm
Capacity (depending on material)	4.5 - 10 m <sup>3</sup> /h

[More product info on our website >>](#)

## Features

- Compact size
- Heavy duty construction
- Low maintenance design
- More than 99.5% clean organic material
- Quick opening doors for easy cleaning
- Bolt free screen exchange
- Low installed power
- Stainless steel isolated splash shields for low noise operation
- Electrical Control Panel

## Optional Extras

- Variety of screen & hopper sizes
- Bin tipper or conveyor infeed options
- Discharge stockpiling conveyors
- Subframe for direct discharge to bins
- Water sprayers for wet processing
- Liquid catchment tank
- Organic discharge pump

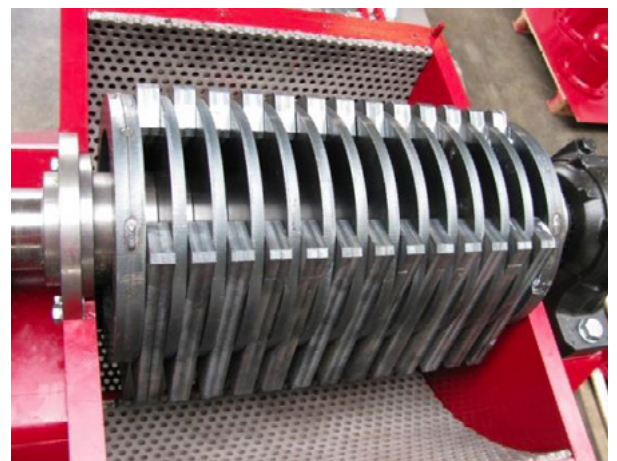

Input



Output

Dimensions and technical information without obligation. Subject to change.

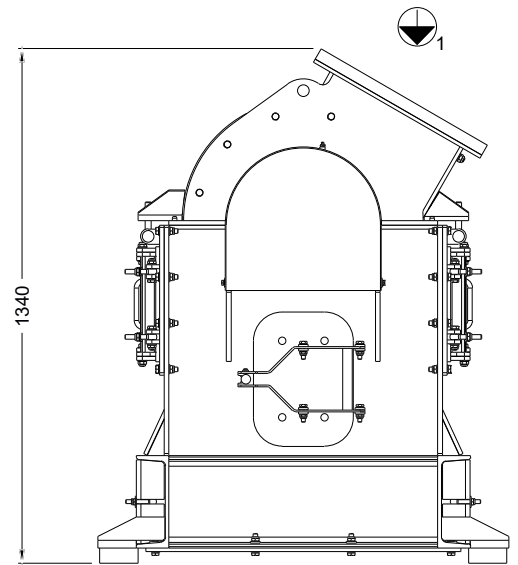
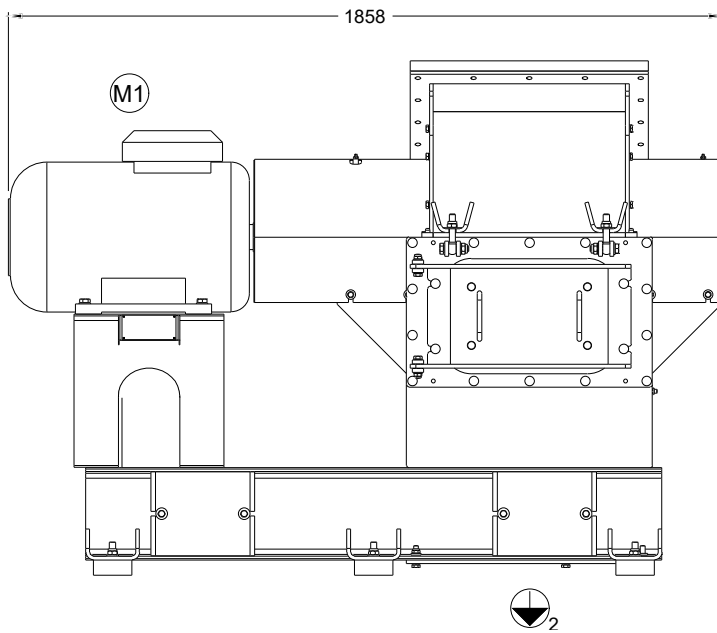
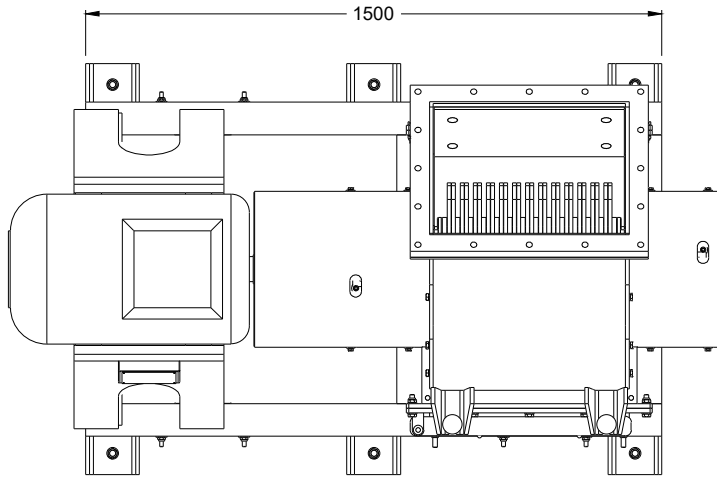

**Approx Weight**  
1100kg



**Motor**  
22-30kW



**Waste Types**  
Packaged food product, Beverage containers

