



Dimensions

| | |
|--------------|---------------|
| Height | 2 700mm |
| Width | 3 100mm |
| Length | 5 100mm |
| Feed Opening | 710 x 1 300mm |

Bale Dimensions

| | |
|----------------|-------------|
| Height | 750mm |
| Width | 750mm |
| Length | Variable |
| Bale Weight | 350-500kg |
| Number of ties | 4 |
| Wire Size | 2.8mm - 4mm |

Performance

| Motor | 20HP | 30HP | 40HP |
|------------------|--------------------|------|------|
| Oil Reservoir | 600L | 600L | 600L |
| Throughput (TPH) | 3-5 | 4-6 | 5-8 |
| Machine Weight | 9T | 9T | 9T |
| Power Supply | 415 V 3-Phase | | |
| Pressing Force | 37T (optional 53T) | | |

Features

- Hardox Bale Chamber
- CAT3 Electrical Safety
- Touchscreen HMI
- Remotely Programmable
- Wire coil dispensers
- Raised bale floor for ease of cleaning
- Interlocked maintenance access doors
- Wire pusher can be placed on either side
- Multi-Linkage jaw clamp for denser bales

Optional Extras

- Feed conveyor
- De-blocking Ram
- Newsprint/Paper Fluffers
- Bin Lifter feeding
- Vertical wire pusher
- Vertical & Horizontal ties
- Bale exit guides
- Hardox upgrades



Dimensions and technical information without obligation. Subject to change.

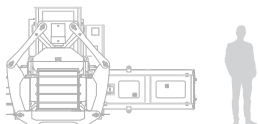
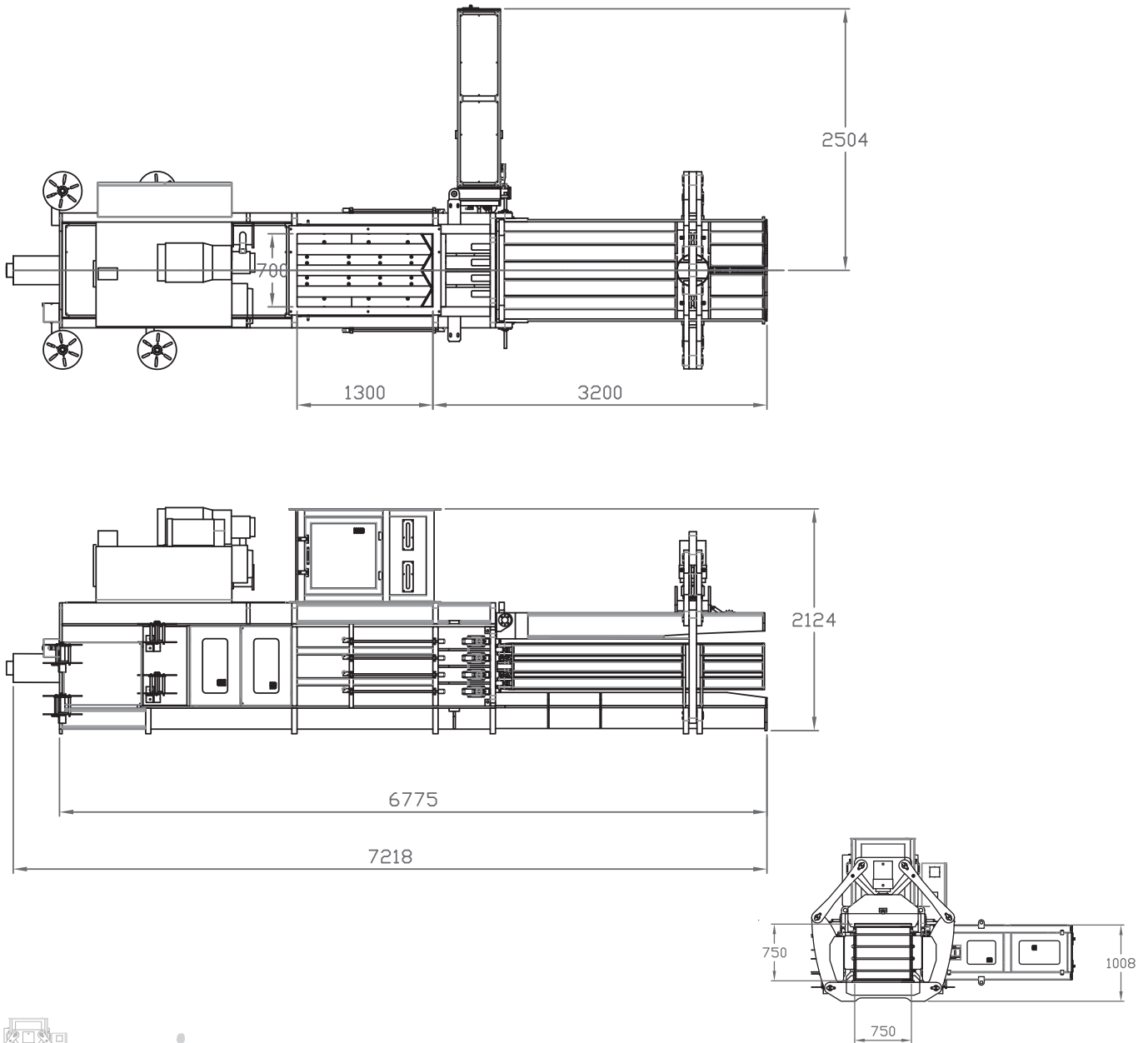

Size Comparison



Bale Weight
Up to 500 Kg



Pressing Force
Up to 53 Ton

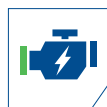

Motor
20/30/40HP



Waste Types
Cardboard, Paper,
Plastics, MSW

